

規格Specification



額定電壓 Rated Voltage	12V	
額定容量 Rated Capacity	230AH/20Hr/10.5V	端子 Terminal: 螺栓(M8 Bolt)
尺寸 Dimension	長度 Length	480±1mm(18.90in)
	寬度 Width	250±1mm(9.84in)
	高度 Height	213±1mm(8.39in)
	總高度 Total Height	213±1mm(8.39in)
重量 Weight		64.9kg(142.78Pounds)
電槽材質 Container Material	ABS, UL 94V-0 or UL 94-HB 抗酸、抗油、防震 Resist acid, resist oil, resist vibration	氧氣指數 Index of oxygen L.O.I>28%
電解液型式 Type of electrolyte	AGM 不外漏 Non-spillable	

特性 Properties

容量 Capacity 25°C(77°F)	20 小時率 20HR of	11.5A to 10.5V	230.0AH
	5 小時率 5HR of	37.3A to 10.5V	186.5AH
	1 小時率 1HR of	149.5A to 10.5V	149.5AH
	0.5 小時率 0.5HR of	241.5A to 10.5V	120.7AH
內阻 Internal Resistance (at 1KHz)	完全充電 Full Charge at 25°C(77°F)		大約 Approx. 2.8mΩ
容量受溫度影響 The capacity will be effected by temperature	40°C(104°F)		105%(20HR to 241AH)
	25°C(77°F)		100%(20HR to 230AH)
	0°C(32°F)		85%(20HR to 195AH)
	-20°C(-4°F)		60%(20HR to 138AH)
最大放電電流 5 秒 Maximum Discharge Current at 5 Sec			1495.0A(6.5CA)
浮充 Float Charging	電壓 Voltage	13.65±0.15V 25°C(77°F)	
	電流 Current	69.00A(0.3CA)	
循環充電 Cyclic Charging	電壓 Voltage	14.70±0.30V 25°C(77°F)	
	電流 Current	57.50A(0.25CA)	
操作溫度 Operation Temperature Range	充電 Charge/放置 Storage: -15~50°C(5~122°F), 放電 Discharge: -20~50°C(-4~122°F)		
期待壽命 Expected Life	25°C(77°F) 10~12 years		
性能特點 Performance characteristics	<p>擁有超級電容瞬間大容量充電的優點，也發揮了鉛酸電池的比能量優勢，且非常好的充電性能，優異的低溫啟動能力，更長的循環壽命。</p> <p>Has the advantages of instantaneous supercapacitor charging capacity, but also play a lead-acid batteries than the energy advantages, and very good charging performance, excellent low temperature start-up ability, longer cycle life.</p>		

尺寸 Dimension: inch (mm)

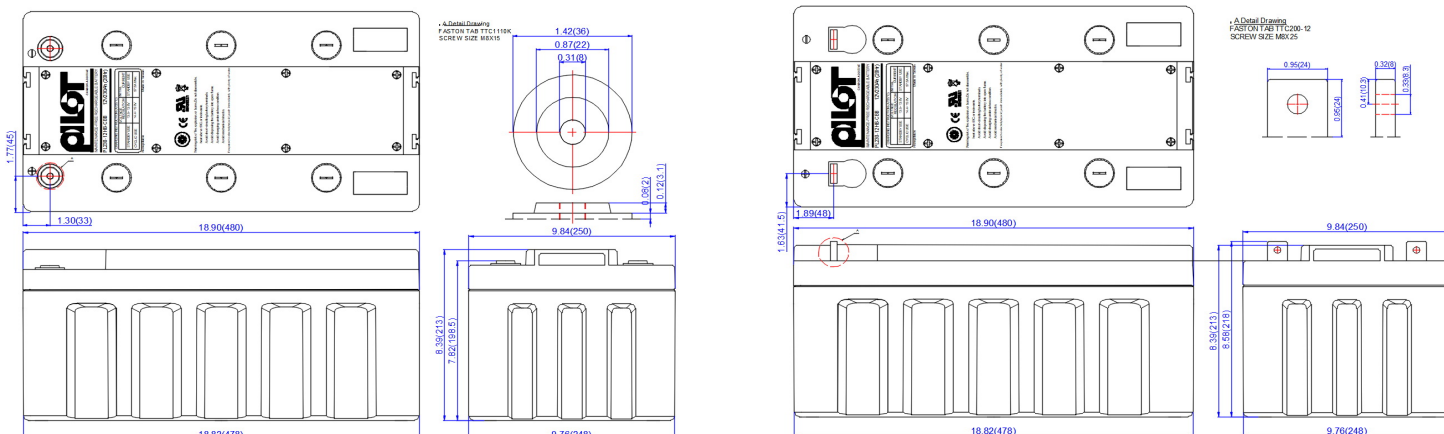

Performance specification Amperes and watts per battery at 25°C (77°F)

F.V.	Time Item	Minutes										Hours							
		5	10	15	20	25	30	35	40	45	1	2	3	4	5	8	10	20	
1.60 (9.60)	A	694.6	512.9	416.3	365.7	305.9	273.7	248.4	230.0	209.3	161.0	92.0	64.4	50.6	40.9	26.7	23.5	12.9	
	W	7293	5385	4579	4023	3518	3148	2857	2645	2407	1852	1076	753	592	491	321	282	155	
1.65 (9.90)	A	637.1	473.8	391.0	340.4	289.8	257.6	234.6	216.2	197.8	156.4	90.9	63.6	49.5	40.5	26.2	23.0	12.7	
	W	6690	4975	4301	3744	3333	2962	2698	2486	2275	1799	1063	745	579	486	314	276	152	
1.70 (10.2)	A	611.8	439.3	368.0	319.7	276.0	248.4	225.4	204.7	193.2	151.8	88.6	62.1	47.7	39.6	25.6	21.6	12.0	
	W	6424	4613	4048	3517	3174	2857	2592	2354	2222	1746	1036	727	558	475	307	259	144	
1.75 (10.5)	A	579.6	402.5	342.7	303.6	264.5	241.5	216.2	197.8	184.0	149.5	84.0	58.3	45.4	37.3	25.0	20.7	11.5	
	W	6086	4226	3770	3340	3042	2777	2486	2275	2116	1719	982	682	531	447	300	248	138	
1.80 (10.8)	A	524.4	365.7	312.8	278.3	250.7	225.4	207.0	188.6	179.4	144.9	80.5	57.5	44.3	36.3	24.2	20.2	11.3	
	W	5506	3840	3441	3061	2883	2592	2381	2169	2063	1666	942	673	518	436	290	243	135	
1.83 (10.98)	A	483.0	289.8	269.1	232.3	213.9	200.1	179.4	161.0	154.1	138.0	79.4	54.4	42.0	34.0	23.6	18.9	10.6	
	W	5072	3043	2960	2555	2460	2301	2063	1852	1772	1587	928	637	491	408	283	226	127	

用途 Application

- ☆ UPS 緊急備用電源
UPS emergency backup power
- ☆ 通信系統
Communication back-up systems
- ☆ 電力系統
Power systems
- ☆ 太陽能儲備系統
Solar storage power systems
- ☆ 緊急照明
Emergency lighting
- ☆ 防火、保全系統
Fire, security systems

密閉結構 Seal construction

- ☆ 沒有漏酸的危險，氣體釋放率超低，不需加水，能防止電解液乾枯或產生層化現象(於放電時)再組合率大於 98%
- Non-spillable, no leaking danger, the gas consumption rate is low, no need to replenish water, can avoid acid lack or crystallization problem during discharge, the recombination rate is higher than 98%
- ☆ 極柱採用鉛錫合金或合金銅鍍鉛材質
The polarities adopted Antimony-Lead alloy or copper alloy covered with Lead material.

穩定性 Stabilities

- ☆ 正負極板是鉛銀合金
Positive and negative plates are lead silver alloy.
- ☆ 塑膠殼是防火 ABS 或等級是 UL 94V-0 L.O.I.>28%
- The plastic material is fire-resistance ABS or same grade of UL 94V-0 L.O.I. >28%
- ☆ 組立用螺絲採用 M8 螺絲，扭力從 7N-m 至 10N-m(最大)採用不銹鋼材質，堅固耐用。
Assembling screws using M8 screws, torque from 7N-m to 10N-m (maximum) made of stainless steel, durable.

放電特性(25°C)

Discharge characteristic at different rates(25°C)

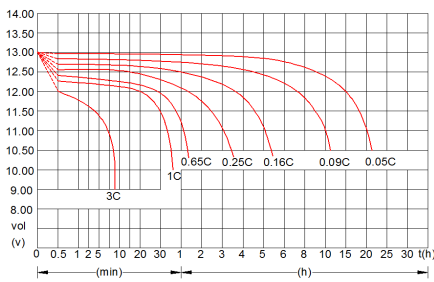

定電壓充電(25°C)

Charging Characteristics

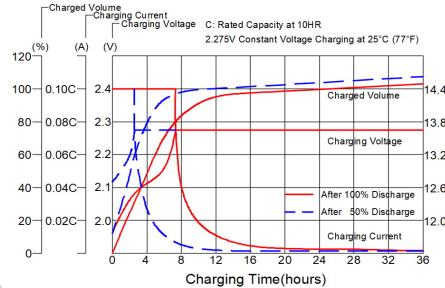

壽命與溫度關係

Accelerated Life Characteristic

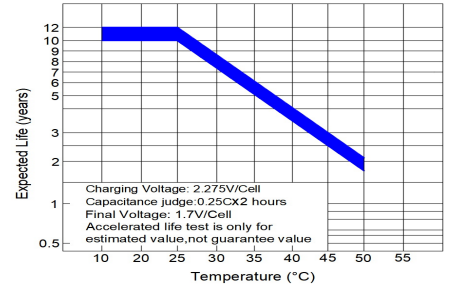

溫度與充電電壓關係

Relationship Between Temperature And Charging Voltage

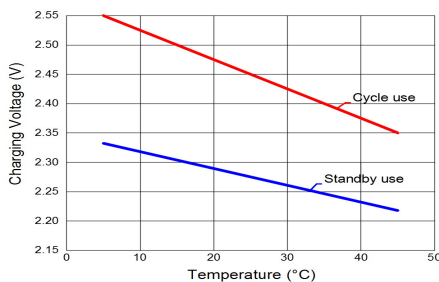

容量保持特性

Capacity Retention Characteristics

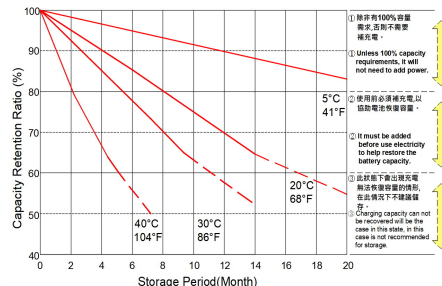

壽命循環關係

Cycle Service Life

